

SOLUTION KEY

Prof. Mikko Lipasti

TAs: Chao Wang, Aditya Godse, Andrew Nere, Erika Gunadi, and Atif Hashmi

Problem 1: (8 points)

- (a) If initially $R1 = 3$ and $R2 = -3$, what is the value of the PC after the following instructions are executed?

x3018:	0101 011 001 000 010	AND r3 r1 r2
x3019:	0000 010 000 000 100	brz pc + 4

PC = x301A

- (b) What is the final value of R2 after this program executes? ($R2 = 1$, $R4 = 6$ initially)

x4001:	0001 010 010 000 010	Add r2,r2,r2
x4002:	0001 100 100 111 111	Add r4,r4,#-1
x4003:	0000 001 111 111 101	BRp here

64

Problem 2: (8 points)

If the number of registers in LC3 is doubled, what would be the effect on:

- (a) The offset field of the LEA instruction

Offset becomes 8 bit: -128 to 127

- (b) The range of addresses a BR instruction can have

No Change

Problem 3: (8 points)

How will you implement the following operation in LC3?

$R2 = R3 \text{ NOR } R4$

Write the machine code (binary 16 bit instructions) in the space below.

<i>NOT R3, R3</i>	<i>1001 011 011 111 111</i>
<i>NOT R4,R4</i>	<i>1001 100 100 111 111</i>
<i>AND R2,R3,R4</i>	<i>0101 010 011 000 100</i>

Problem 4: (10 points)

Shown here are the contents of memory before and after the LC3 instruction at location x3010 is executed. Your job: Identify the instruction stored in x3010. Note: There is enough information below to uniquely specify the instruction at x3010.

	Before	After
R0	x3208	x3208
R1	x2d7c	x2d7c
R2	xe373	xe373
R3	x2053	x2053
R4	x33ff	x33ff
R5	x3f1f	x3f1f
R6	xf4a2	xf4a2
R7	x5220	x5220
...		
x3400	x3001	x3001
x3401	x7a00	x7a00
x3402	x7a2b	x7a2b
x3403	xa700	xa700
x3404	xf011	xf011
x3405	x2003	x2003
x3406	x31ba	X31ba
x3407	xc100	xe373
x3408	xefef	xefef

x3010: STR R2, R4, #8 (0111010 100 001000)

Problem 5: (6 points)

Explain in brief, the difference between:

(a) Trap and jump instructions

Trap: Target address is obtained via a table, RET causes old PC to be restored

Jump: Target address specified by user through a register, PC is not saved

(b) Breakpoints and watchpoints

Breakpoints: Program stops executing where we set the breakpoint

Watchpoints: Execution stops when the variable being watched changes

(c) Data errors and logic errors

Data errors: Input data is different than expected

Logic errors: Program is legal but logically wrong

Problem 6: (8 points)

Let R1, R2 and R3 hold some values. Draw a flowchart to store the greatest of these values in R5. Your flowchart must consist of blocks which correspond to groups of LC3 instructions.

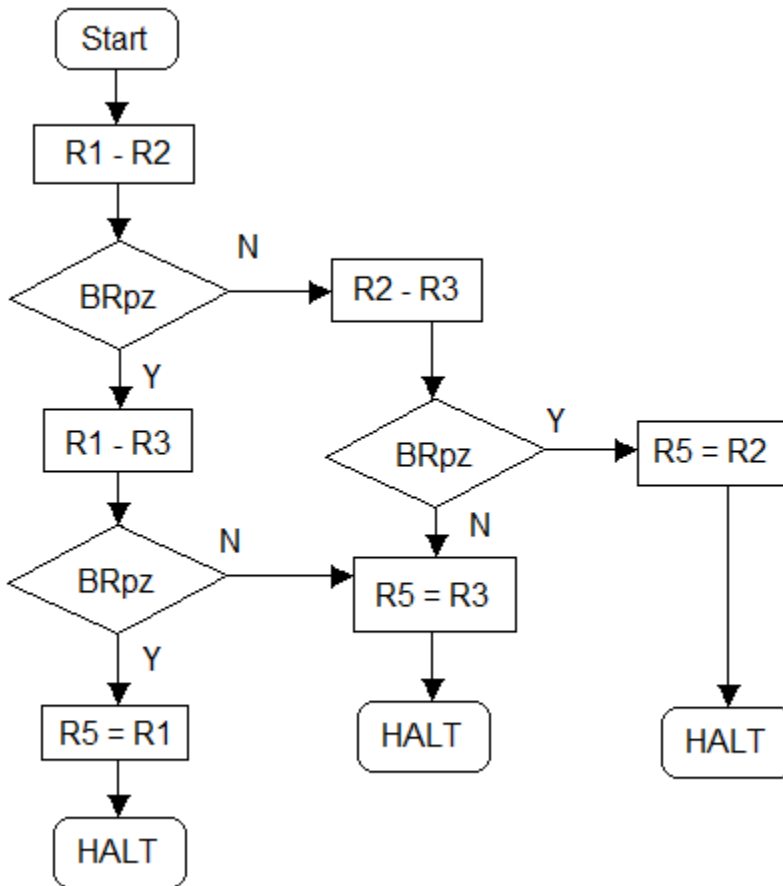

Problem 7: (8 points)

We are about to execute the following program:

Address	ISA Instruction
x3000	1110 0000 0000 1110 ; LEA R1, x00B
x3001	0010 0010 0000 1110 ; LD R0, x00D
x3002	0110 0100 1100 1110 ; LDR R2, R3, x0B
x3003	1111 0000 0010 0101 ; HALT

The state of the machine before the program starts is given below:

Memory location x300B contains x311B

Memory location x300C contains xC465

Memory location x300E contains xFE12
Register R0 and R1 contain x0000

Memory location x300F contains x1243
Registers R2 and R3 contain x3000

What will be the final contents of registers R0-R3 when we reach the HALT instruction? Write your answers in hexadecimal format.

R0 = x1243

R1 = x300C

R2 = x311B

R3 = x3000

Problem 8: (4 pts)

Consider the following snippets of LC3 code which achieve the same function:

- (i) LDI R5, LABEL_1 where LABEL_1 = x4010
- (ii) LD R5, LABEL_2 where LABEL = x400E
LDR R5, R5, #2

What is the advantage of using (i) over (ii)?

More compact

What is the advantage of using (ii) over (i)?

More flexible because of the offset